

CAST GLOBE VALVE

Class 150 LBS

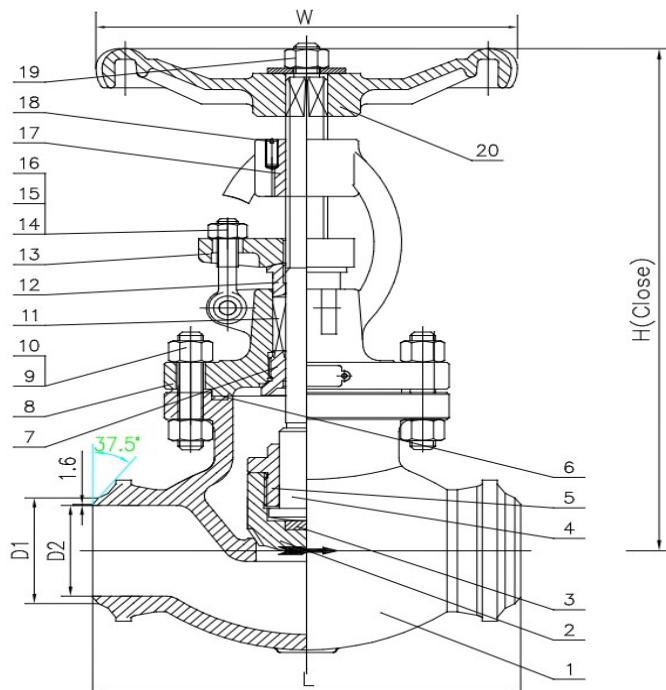

Basic design features

Design	BS1873 /ASME B16.34
Face to face	ASME B16.10
BW	ASME B16.25
Testing	API 598
Bore	FULL
Bonnet	BOLTED
Marking	CE - PED
Certificates	EN 10204 - 3.1 / 3.2
Rating	150 LBS

Test Pressure to API 598

Class	150 LBS
Shell (Water)	30 bar
Seat (Water)	22 bar
Seat (Air)	6.0 bar

BILL OF MATERIALS STANDARD ACCORDING TO ASTM

	PART NAME	WCB	LCB	CF8M
1	BODY	ASTM A 216 WCB	ASTM A352 LCB+STL	ASTM A351 CF8M
2	DISC	ASTM A 105	ASTM LF2+316	ASTM A182 F316
3	THRUST PLATE	ASTM A276 410	ASTM A 276 410	ASTM A276 316
4	STEM	ASTM A 182 F6a	ASTM A 182-F316	ASTM A 182-F316
5	DISC NUT	AISI 1025	AISI 1025	ASTM A276 316
6	GASKET	304+GRAPHITE	316+GRAPHITE	316+GRAPHITE
7	BACK SEAT	ASTM A 182 F6a	ASTM A 182 F6a	INTEGRAL
8	BONNET	ATM A 216 WCB	ASTM A352 LCB	ASTM A351 CF8M
9	BOLT	ASTM A 193 B7M	ASTM A 193-L7M	ASTM A 193 B8
10	NUT	ASTM A 194-2HM	ASTM A 194 L7M	ASTM A 194-8
11	PACKING	GRAPHITE	GRAPHITE	GRAPHITE
12	PACKING GLAND	ASTM A 276 410	ASTM A 276-410	ASTM A276 316
13	GLAND FLANGE	ASTM A105	ASTM A 105	ASTM A 351 CF8M
14	PIN	AISI 1035	AISI 1035	ASTM A276 316
15	NUT	ASTM A 194-2HM	ASTM A 194-7M	ASTM A 194-8
16	EYE-BOLT	ASTM A193-B7M	ASTM A193 L7M	ASTM A193-B8
17	STEM NUT	COPPER ALLOY	COPPER ALLOY	COPPER ALLOY
18	SCREW	AISI 1035	AISI 1035	AISI 1035
19	NUT	AISI 1025	AISI 1025	AISI 1025
20	HANDWELL	A536 Gr60-40-18	A536 Gr60-40-18	A536 Gr60-40-18

On requests available in: LCC-C5-C12-WC6-WC9-C12A-CF8-CF3-CF3M & trim No. 1, 5, 8, 10, 12, 16, ...

Gear recommended from 16"

This document is the property of OPM ITALIA Srl. It must not be stored, reproduced or disclosed to others without Our written authorisation.

All data, subject to technical changes, are only for information and not for official use



CAST GLOBE VALVE

Class 150 LBS

SIZE INCH	L (MM)	H (CLOSE-MM)	W (MM)
2	203	312	200
2 ½	216	312	250
3	241	364	250
4	292	412	300
5	356	448	350
6	406	478	400
8	495	554	450
10	622	771	500
12	698	842	500

O.P.M. ITALIA Srl Via Murri, 40 20013 Magenta - MI Italy Phone +39 02 97003091

www.opmitalia.com / email : info@opmitalia.com