

CAST GATE VALVE

Class 150 LBS

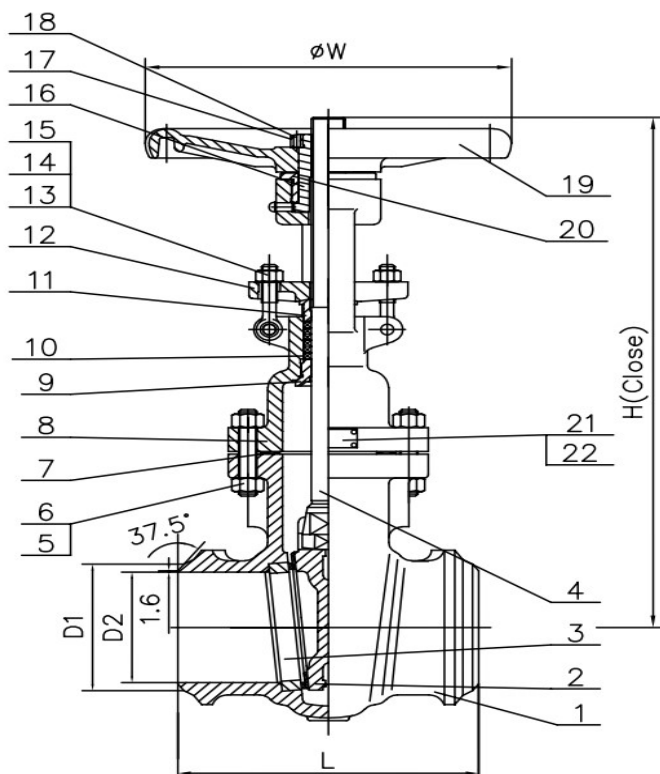

Basic design features

Design	API 600 /ASME B16.34
Face to face	ASME B16.10
BW DIMENSION	ASME B16.25
Testing	API 598
Bore	FULL
Bonnet	BOLTED
Marking	CE - PED
Certificates	EN 10204 - 3.1 / 3.2
Rating	150 LBS

Test Pressure to API 598

Class	150 LBS
Shell (Water)	30 bar
Seat (Water)	22 bar
Seat (Air)	6.0 bar

BILL OF MATERIALS STANDARD ACCORDING TO ASTM

	PART NAME	WCB	LCB	CF8M
1	BODY	ASTM 216 WCB	ASTM A 352 LCB	ASTM A 351 CF8M
2	WEDGE	ASTM A 216 WCB	ASTM A 352 LCB+STL	ASTM A 351 CF8M
3	SEAT	ASTM A 105	INT+STL	INTEGRAL
4	STEM	ASTM A 182 F6a	ASTM A182 F316	ASTM A 182 F316
5	BOLT	ASTM A193-B7M	ASTM A193 L7M	ASTM A 193-B8
6	HEX NUT	ASTM A 194-2HM	ASTM A194-7M	ASTM A194-8
7	GASKET	304+GRAPHITE	304+GRAPHITE	316+GRAPHITE
8	BONNET	ASTM A 216 WCB	ASTM A 352 LCB	ASTM A 351 CF8M
9	BACKSEAT	ASTM A 276-410	ASTM A276-410	INTEGRAL
10	PACKING	GRAPHITE	GRAPHITE	GRAPHITE
11	PACKING GLAND	ASTM A 276-410	ASTM A 276-410	ASTM A 276-316
12	GLAND FLANGE	ASTM A 105	ASTM A 105	ASTM 316
13	EYE-BOLT	ASTM A 193 B7M	ASTM A 193 L7M	ASTM A193-B8
14	HEX. NUT	ASTM A 194-2HM	ASTM A 194 7M	ASTM A 194-8
15	PIN	AISI 1035	AISI 1035	AISI 1035
16	STEM NUT	COPPER ALLOY	COPPER ALLOY	COPPER ALLOY
17	LOCKING NUT	AISI 1035	AISI 1035	AISI 1035
18	SCREW	ASTM A 36	ASTM A36	ATM A 36
19	HANDWHEEL	A536 Gr60-40-18	A536 Gr60-40-18	A536 Gr60-40-18
20	BEARING COVER	AISI 1025	AISI 1025	AISI 1025
21	NAMEPLATE	SS	SS	SS
22	RIVET	AL	AL	AL

On requests available in: LCC-C5-C12-WC6-WC9-C12A-CF8-CF3-CF3M & trim No. 1, 5, 8, 10, 12, 16, ...

Gear recommended from 16"

This document is the property of OPM ITALIA Srl. It must not be stored, reproduced or disclosed to others without Our written authorisation.

All data, subject to technical changes, are only for information and not for official use



CAST GATE VALVE Class 150 LBS

SIZE INCH	L (MM)	H (CLOSE-MM)	W (MM)
2	216	345	180
2 ½	241	375	200
3	282	418	250
4	305	490	280
5	381	537	280
6	403	605	300
8	419	740	350

O.P.M. ITALIA Srl Via Murri, 40 20013 Magenta - MI Italy Phone +39 02 97003091

www.opmitalia.com / email : info@opmitalia.com