

FORGED GLOBE VALVE

Class 800 WB

Basic design features

Design	ISO 15761-API 602
Face to face	ASME B16.10
Ends Dimensions	SW according to ANSI B16.11/ NPT-F according to
Testing	API 598
Bore	REDUCED-FULL
Bonnet	BOLTED
Marking	CE - PED
Certificates	EN 10204 - 3.1 / 3.2
Rating	800 LBS

Test Pressure to API 598

Class	800 LBS
Shell (Water)	211 bar
Seat (Water)	155 bar
Seat (Air)	6.0 bar

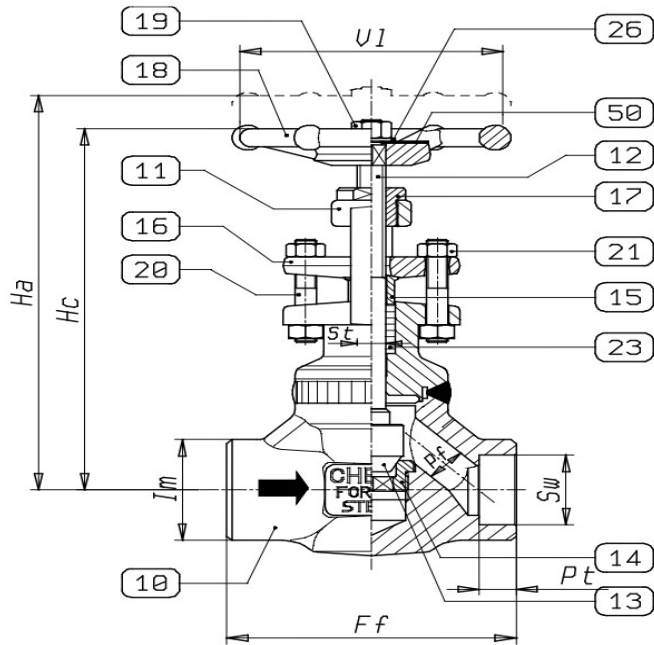

BILL OF MATERIALS STANDARD ACCORDING TO ASTM

	Part Nam	A105	A350 LF2	A182 F11
10	Body	ASTM A105N	/	/
11	Bonnet	ASTM A 105N	/	/
12	Stem	ASTM A 182 F6a	/	/
13	Disc	ASTM A182 F6a	/	/
14	Seat	ASTM A182 F6a	/	/
15	Gland	AISI 316	/	/
16	Gland Flange	ASTM A 105N	/	/
17	Stem nut	AISI 416	/	/
18	Handwell	ASTM A105	/	/
19	Handwell nut	CARBON STEEL	/	/
20	Gland stud bolt	AISI 410	/	/
21	Gland nut	ASTM A194 2H	/	/
23	Packing	GRAPHITE	/	/
50	Namplate	ALLUMINIUM	/	/
26	Handwell washer	CARBON STEEL	/	/

*VS 215 C30 - VS 215 C31

*Body Material available in: A182 F5 - A182 F22 - A182 F91 - A182 F304 - A182 F347- A182 F321 - A182 F44 - A182 F51 - A182 F53-A350 LF2-A182 F11-A182 F316

On request TRIM: with Stellite , Monel, Hastelloy, Inconel, Alloy, other material



**FORGED GLOBE VALVE
Class 800 WB (REDUCED
BORE)**

SIZE INCH	Ff (MM)	Hc (MM)	Im (MM)	Vi (MM)
1/4"	/	/	/	/
3/8"	/	/	/	/
1/2"	80	141	33	90
3/4"	90	154	39	100
1"	110	180	49	120
1-1/4"	127	220	64	120
1-1/2"	145	241	64	140
2"	170	277	78	175

O.P.M. ITALIA Srl Via Murri, 40 20013 Magenta - MI Italy Phone +39 02 97003091
www.opmitalia.com / email : info@opmitalia.com