

FORGED GLOBE VALVE

Class 800 WB - VD 415 D40

Basic design features

Design	ISO 15761-API 602
Face to face	ASME B16.10
Ends Dimensions	SW according to ANSI B16.11/ NPT-F according to
Testing	API 598
Bore	REDUCED-FULL
Bonnet	BOLTED
Marking	CE - PED
Certificates	EN 10204 - 3.1 / 3.2
Rating	800 LBS

Test Pressure to API 598

Class	800 LBS
Shell (Water)	211 bar
Seat (Water)	155 bar
Seat (Air)	6.0 bar

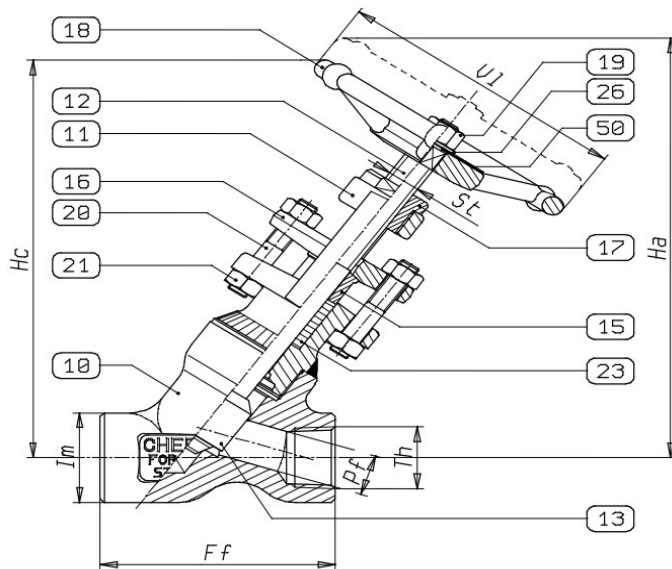

BILL OF MATERIALS STANDARD ACCORDING TO ASTM

Part Nam	A105	A350 LF2	A182 F11
10 Body	ASTM A105N	/	/
11 Bonnet	ASTM A 105N	/	/
12 Stem	ASTM A 182 F304	/	/
13 Disc	ASTM A182 F304+STL	/	/
15 Packing gland	AISI 316	/	/
16 Gland flange	ASTM A105N	/	/
17 Stem nut	ASTM A 105NAISI 416	/	/
18 Handwell	CARBON STEEL	/	/
19 Handwell nut	CARBON STEEL	/	/
20 Gland stud bolt	CARBON STEEL AISI 410	/	/
21 Gland nuts	ASTM A194 2H	/	/
23 Packing	GRAPHITE	/	/
26 Handwell washer	CARBON STEEL	/	/
50 Namplate	ALLUMINIUM	/	/

*Body Material available in: A182 F5 - A182 F22 - A182 F91 - A182 F304 - A182 F347- A182 F321 - A182 F44 - A182 F51 - A182 F53-A350 LF2-A182 F11-A182 F316

On request TRIM: with Stellite , Monel, Hastelloy, Inconel, Alloy, other material



FORGED GLOBE VALVE
Class 800 WB - VD 415 D40
(REDUCED BORE)

SIZE INCH	Ff (MM)	Hc (MM)	Im (MM)	Vi (MM)
1/4"	/	/	/	/
3/8"	/	/	/	/
1/2"	80	151	33	90
3/4"	100	174	40	100
1"	110	211	49	120
1-1/4"	120	215	56	140
1-1/2"	160	278	72	200
2"	190	314	85	200

O.P.M. ITALIA Srl Via Murri, 40 20013 Magenta - MI Italy Phone +39 02 97003091
www.opmitalia.com / email : info@opmitalia.com