

FORGED GATE VALVE

Class 800 LBS

Basic design features

Design	ISO 15761-API 602
Face to face	ASME B16.10
ENDS DIMENAIIONS	SW according to ANSI B16.11/ NPT-F according to ASME B1.20.1
Testing	API 598
Bore	REDUCED-FULL
Bonnet	BOLTED
Marking	CE - PED
Certificates	EN 10204 - 3.1 / 3.2
Rating	800 LBS

Test Pressure to API 598

Class	800 LBS
Shell (Water)	211 bar
Seat (Water)	155 bar
Seat (Air)	6.0 bar

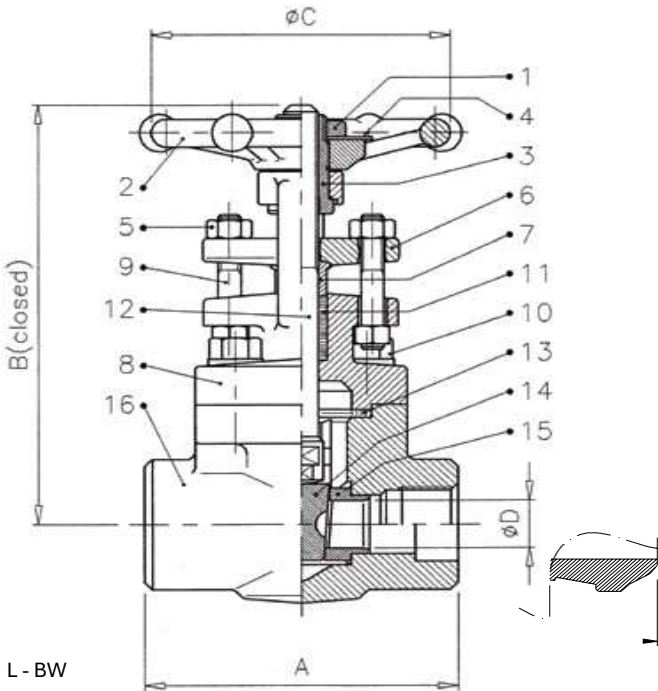

BILL OF MATERIALS STANDARD ACCORDING TO ASTM

	PART NAME	A105	A350 LF2	A182 F11	A182 F316
1	Handwheel Nut	CS	CS	CS	CS
2	Handwheel	CS	CS	CS	Carbon Steel RILSAN
3	Yoke Sleeve	AISI 416	AISI 416	AISI 416	AISI 416
4	Nameplate	Aluminium	Aluminium	Aluminium	Aluminium
5	Gland Nut	ASTM A194 Gr 2H	ASTM A194 GR.8	ASTM A194 Gr 2H	ASTM A194 Gr.8
6	Gland Flange	ASTM A105N	ASTM A350 LF2	ASTM A105N	ASTM A182F316
7	Packing Gland	ASTM A182 F316	ASTM A182 F316	ASTM 182 F316	ASTM A182 F316
8	Bonnet	ASTM A105N	ASTM A350 LF2	ASTM A182 F11	ASTM A182 F316
9	Gland Studs	AISI 410	ASTM A193 B8	AISI410	ASTM A193 B8
10	Bolt B/B	ASTM A193 B7	ASTM A193 L7	ASTM A193 B16	ASTM A193 B8
11	Packing	Graphite	Graphite	Graphite	Graphite
12	Stem	ASTM A182 F6	ASTM A182 F6	ASTM A182 F6	ASTM 183 F316
13	Gasket B/B	F316 + Graphite	F316 + Graphite	F316 +Graphite	F316 + Graphite
14	Wedge	ASTM A182 F6	ASTM A182 F6	ASTM A182 F6	ASTM A182 F316
15	Seat	ASTM A182 F6	ASTM A182 F6	ASTM A182 F6	ASTM A182 F316
16	Body	ASTM A105N	ASTM A350 LF2	ASTM A182 F11	ASTM A182 F316

*Body Material available in: A182 F5 - A182 F22 - A182 F91 - A182 F304 - A182 F347- A182 F321 - A182 F44 - A182 F51 - A182 F53

On request TRIM: with Stellite , Monel, Hastelloy, Inconel, Alloy, other material



FORGED GATE VALVE
Class 800 LBS (REDUCED BORE)

SIZE INCH	A (MM)	B (MM)	C (MM)	D (MM)
1/4"	/	/	/	/
3/8"	/	/	/	/
1/2"	80	135	90	10
3/4"	90	138	90	14
1"	110	166	100	18
1-1/4"	127	204	120	24
1-1/2"	127	208	140	29
2"	130	234	140	36.5



FORGED GATE VALVE
Class 800 LBS
(FULL BORE)

SIZE INCH	A (MM)	B (MM)	C (MM)	D (MM)
1/4"	80	130	90	8.5
3/8"	80	130	90	10
1/2"	90	138	90	14
3/4"	110	166	100	18
1"	127	204	120	24
1-1/4"	127	208	140	29
1-1/2"	130	234	140	36.5
2"	210	285	200	48

O.P.M. ITALIA Srl Via Murri, 40 20013 Magenta - MI Italy Phone +39 02 97003091

www.opmitalia.com / email : info@opmitalia.com