

CAST CHECK DUAL PLATE VALVE Class 600 LBS

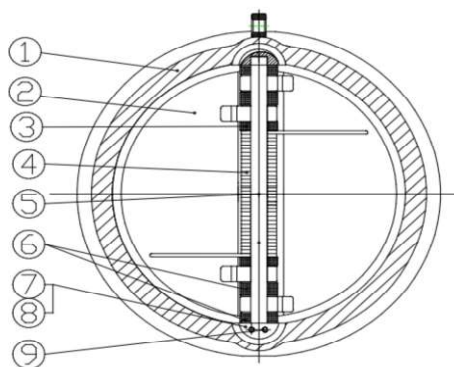
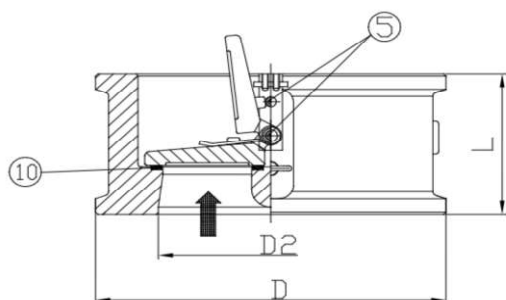

Basic design features

Design	API 594 / ASME B16.34
Face to face	API 594
Flanges	ASME B16.5
Testing	API 598
Bore	FULL
Bonnet	BOLTED
Marking	CE - PED
Certificates	EN 10204 - 3.1 / 3.2
Rating	600 LBS

Test Pressure to API 598

Class	600 LBS
Shell (Water)	153 bar
Seat (Water)	113 bar
Seat (Air)	6.0 bar

BILL OF MATERIALS STANDARD ACCORDING TO ASTM

	PART NAME	WCB	CF3M	CF8M
1	BODY	A216 WCB	A351 CF3M	A351 CF8M
2	DISC	A351 CF8M	A351 CF3M	A351 CF8M
3	SPRING SEAT	SS316	SS316L	SS316
4	SPRING	INCONEL X750	INCONEL X750	INCONEL X750
5	SHAFT	SS316	SS 316L	SS316
6	WASHER	SS316	SS 316L	SS316
7	SHAFT SEAT	SS316	SS 316L	SS316
8	LOCATION	SS316	SS 316L	SS316
9	BOLT	SS316	SS316L	SS316
10	SEAT SEALING FACE	316 OVERLAY	316L OVERLAY	316 OVERLAY

On requests available in: LCC-C5-C12-WC6-WC9-C12A-CF8-CF3-CF3M

This document is the property of OPM ITALIA Srl. It must not be stored, reproduced or disclosed to others without Our written authorisation.

All data, subject to technical changes, are only for information and not for official use



CAST CHECK DUAL PLATE VALVE Class 600 LBS

SIZE INCH	L (MM)	D (MM)	D2 (MM)
2	60	110	51
2 ½	67	128	65
3	73	147	80
4	79	191	102
5	/	/	/
6	136	264	152
8	165	318	200
10	213	398	250
12	229	455	305
14	273	490	340
16	305	562	390
18	362	610	440
20	368	680	490
24	438	786	590

O.P.M. ITALIA Srl Via Murri, 40 20013 Magenta - MI Italy Phone +39 02 97003091
www.opmitalia.com / email : info@opmitalia.com