

CAST STEEL BALL VALVE FLOATING Class 300 LBS

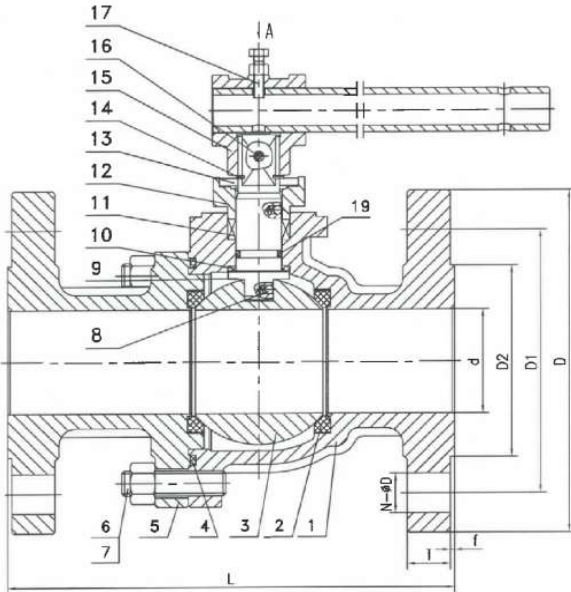

Basic design features

Design	API 6D
Face to face	ASME B16.10
Flanges	ASME B16.5
Testing	API 598
Bore	FULL
Bonnet	BOLTED
Marking	CE - PED
Fire Safe	API 607
Certificates	EN 10204 - 3.1 / 3.2
Rating	300 LBS

Test Pressure to API 598

Class	300 LBS
Shell (Water)	77 bar
Seat (Water)	57 bar
Seat (Air)	6.0 bar

BILL OF MATERIALS STANDARD ACCORDING TO ASTM

	PART NAME	WCB	CF8M	LCB
1	BODY	ASTM A216 WCB	ASTM A351 CF8M	/
2	SEAT	RPTFE	RPTFE	/
3	BALL	ASTM A182 F316	ASTM A182 F316	/
4	GASKET	316+GRAPHITE	316+GRAPHITE	/
5	BODY CAP	ASTM A216 WCB	ASTM A51 CF8M	/
6	STUD	A193 B7	A193 B8M	/
7	NUT	A194 2H	A194 8M	/
8	ANTI STATIC DEVICE	ASSEMBLY	ASSEMBLY	/
9	STEM	ASTM A182 F316	ASTM A182 F316	/
10	THURST BEARING	PTFE	PTFE	/
19	O RING	VITON	VITON	/
11	PACKING	GRAPHITE	GRAPHITE	/
12	GLAND	ASTM A216 WCB	ASTM A351 CF8M	/
13	LIMIT BLOCK	A36+HZN	A36+HZN	/
14	SHAFT ELASTIC RING	AISI 1566	AISI 1566	/
15	LEVER	ASTM A216 WCB	ASTM A216 WCB	/
16	BOLT	ASTM A 193 B8	ASTM A 193 B8	/
17	BOLT	ASTM A193 B8	ASTM A193 B8	/



**CAST STEEL BALL
VALVE FLOATING
Class 300 LBS**

SIZE INCH	L (MM)	D (MM)	D1 (MM)	d (MM)
2	216	345	180	/
3	190	375	200	/

O.P.M. ITALIA Srl Via Murri, 40 20013 Magenta - MI Italy Phone +39 02 97003091

www.opmitalia.com / email : info@opmitalia.com