

STRAINER BASKET TEE TYPE

150 – 300 – 600 – 900 Lbs

DT-SB-003

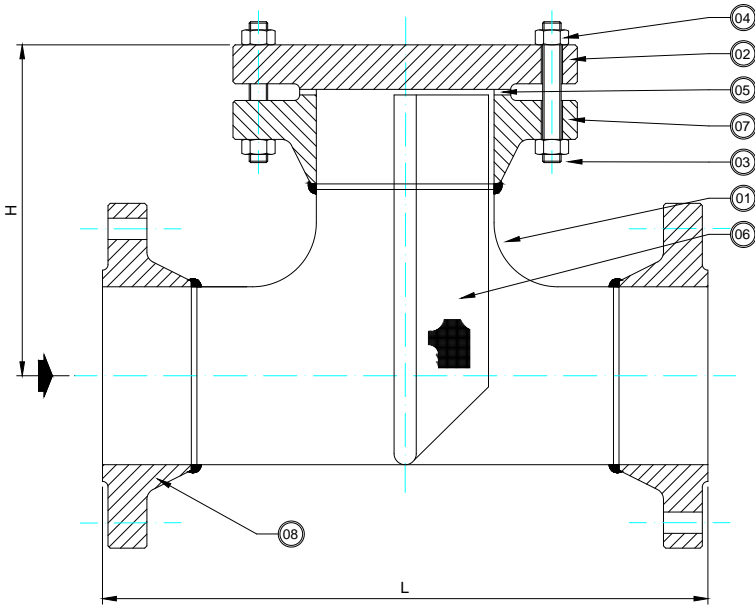

BASIC DESIGN STANDARDS

Basic Design Mfr Std

Face to Face Dimension Manufacturer Standard

Flanges Up to 24" ANSI B16.5
From 26" MSS SP44
ANSI B16.47 API 605

Testing API 598

STANDARD DESCRIPTION

- Tee Pattern
- Bolted Cover
- Stainless steel cartridge
- Mesh according to Customer's requirement.

TEST PRESSURE TO API 598 bar

Shell (water)

Class 150#	Class 300#	Class 600#	Class 900#
30	77	153	230

* Recommended Spare Parts

BILL OF MATERIALS STANDARD ACCORDING TO ASTM

No	Part Name	Carbon Steel		Alloy Steel		Stainless Steel			
		WCB	LCB	WC6	C5	CF8	CF8M	CF3	CF3M
01	Body	A234 WPB	A420 WPL6	A 234 WP11	A234 WP5	A403 WP304	A403 WP316	A403 WP304L	A403 WP316L
02	Cover	A105N	A350 LF2	A182 F11	A182 F5	A182 F304	A182 F316	A182 F304L	A182 F316L
03	Cover Bolts	A193-B7	A320-L7	A193-B16		A193-B8			
04	Cover Nuts	A194-2H	A194-4	A194-4		A194-8			
05	Body / Cover Gasket (*)	Stainless Steel+ Graphite							
06	Cartridge	ASTM A479 TP316							
07	Flange	A105N	A350 LF2	A182 F11	A182 F5	A182 F304	A182 F316	A182 F304L	A182 F316L
08	Flange	A105N	A350 LF2	A182 F11	A182 F5	A182 F304	A182 F316	A182 F304L	A182 F316L

SIZE	CLASS					
	150 Lbs		300 Lbs		600 Lbs	
	L (RF)	H	L (RF)	H	L (RF)	H
2"	254	148	254	158	254	177
3"	312	182	312	197	312	216
4"	363	208	363	225	363	260
6"	464	260	464	281	464	324
8"	560	311	560	333	560	382
10"	636	351	636	385	636	447
12"	737	403	737	438	737	492
14"	814	445	846	480	903	530
16"	864	472	864	511	864	574
18"	966	525	966	565	966	624
20"	1051	571	1051	609	1051	676
24"	1170	635	1170	673	1170	753

This document is the property of OPM Italia Srl. It must not be stored, reproduced or disclosed to others without written authorisation from the Company.