

STRAINER BASKET TEE TYPE

150 – 300 – 600 – 900 Lbs

DT-SB-002

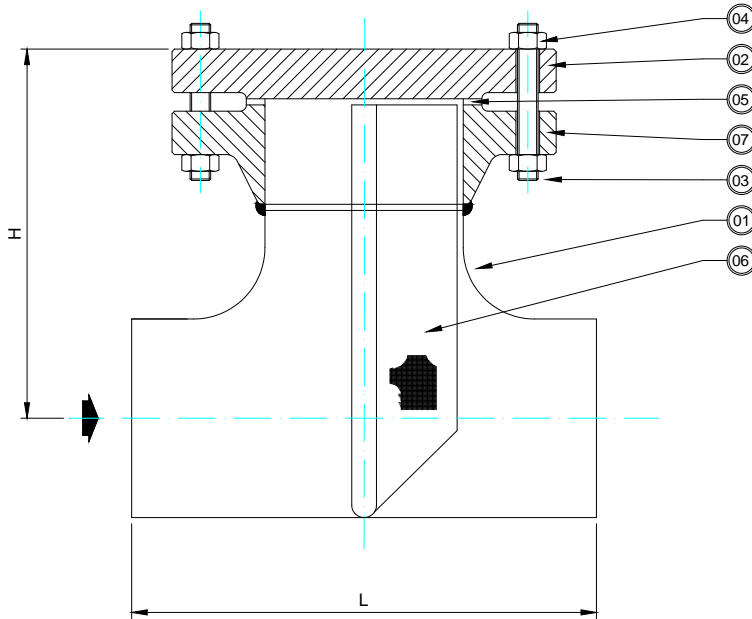

BASIC DESIGN STANDARDS

| | |
|-------------------------------|---|
| Basic Design | <u>Mfr Std</u> |
| Face to Face Dimension | <u>Manufacturer Standard</u> |
| Flanges | <u>Up to 24" ANSI B16.5</u> <u>From 26" MSS SP44</u> <u>ANSI B16.47 API 605</u> |
| Butt-weld ends | <u>ANSI B16.25</u> |
| Testing | <u>API 598</u> |

STANDARD DESCRIPTION

- Tee Pattern
- Bolted Cover
- Stainless steel cartridge
- Mesh according to Customer's requirement.

TEST PRESSURE TO API 598 bar

| | | | |
|---------------|------------|------------|------------|
| Shell (water) | | | |
| Class 150# | Class 300# | Class 600# | Class 900# |
| 30 | 77 | 153 | 230 |

* Recommended Spare Parts

BILL OF MATERIALS STANDARD ACCORDING TO ASTM

| No | Part Name | Carbon Steel | | Alloy Steel | | Stainless Steel | | | |
|----|-------------------------|---------------------------|-----------|-------------|----------|-----------------|------------|-------------|-------------|
| | | WCB | LCB | WC6 | C5 | CF8 | CF8M | CF3 | CF3M |
| 01 | Body | A234 WPB | A420 WPL6 | A 234 WP11 | A234 WP5 | A403 WP304 | A403 WP316 | A403 WP304L | A403 WP316L |
| 02 | Cover | A105N | A350 LF2 | A182 F11 | A182 F5 | A182 F304 | A182 F316 | A182 F304L | A182 F316L |
| 03 | Cover Bolts | A193-B7 | A320-L7 | A193-B16 | | A193-B8 | | | |
| 04 | Cover Nuts | A194-2H | A194-4 | A194-4 | | A194-8 | | | |
| 05 | Body / Cover Gasket (*) | Stainless Steel+ Graphite | | | | | | | |
| 06 | Cartridge | ASTM A479 TP316 | | | | | | | |
| 07 | Flange | A105N | A350 LF2 | A182 F11 | A182 F5 | A182 F304 | A182 F316 | A182 F304L | A182 F316L |

CLASS

| SIZE | L (BW) | CLASS | | | |
|------|--------|---------|---------|---------|---------|
| | | 150 Lbs | 300 Lbs | 600 Lbs | 900 Lbs |
| | | H | H | H | H |
| 2" | 128 | 148 | 158 | 177 | 219 |
| 3" | 172 | 182 | 197 | 216 | 242 |
| 4" | 210 | 208 | 225 | 260 | 279 |
| 6" | 286 | 260 | 281 | 324 | 353 |
| 8" | 356 | 311 | 333 | 382 | 419 |
| 10" | 432 | 351 | 385 | 447 | 485 |
| 12" | 508 | 403 | 438 | 492 | 549 |
| 14" | 559 | 445 | 480 | 530 | 603 |
| 16" | 610 | 472 | 511 | 574 | 626 |
| 18" | 686 | 525 | 565 | 624 | 689 |
| 20" | 762 | 571 | 609 | 676 | 752 |
| 24" | 864 | 635 | 673 | 753 | 879 |