

1500 Lbs

DT-FGV-004

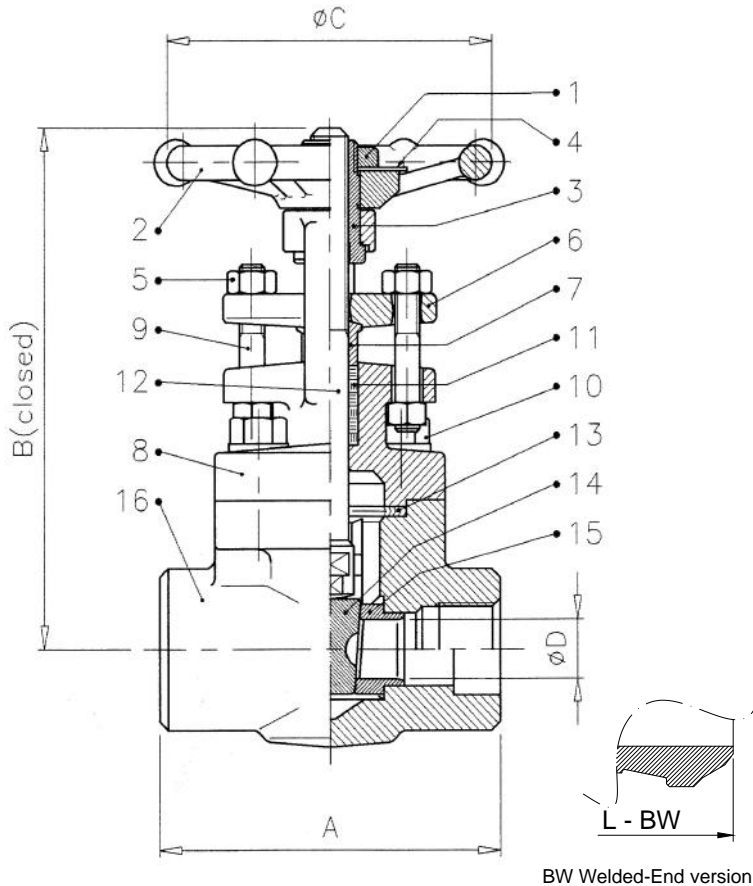

BASIC DESIGN STANDARDS

Basic Design ISO 15761 – API 602

Wall Thickness / Pressure / Temperature According to ANSI B16.34

Ends SW according to ANSI

Dimensions B16.34 / NPT-F according to ASME B1.20

Bore Reduced & Full

TEST PRESSURE TO API 598 bar

Class	Shell (water)	Seat (water)	Seat (air)
1500	382	280	6.0

BILL OF MATERIALS STANDARD ACCORDING TO ASTM

No	Part Name	Carbon Steel		Alloy Steel	Stainless Steel
		A105/F6 (**)	LF2/304	F11/F6 HF (**)	SS316
01	Handwheel Nut	Carbon Steel	Carbon Steel	Carbon Steel	A194 Gr.8
02	Handwheel	Carbon Steel	Carbon Steel	Carbon Steel	Carbon Steel + Rislant
03	Yoke Sleeve	AISI 416	AISI 416	AISI 416	AISI 416
04	Name Plate	Aluminium	Aluminium	Aluminium	INOX
05	Gland Nuts	A194 Gr. 2H	A194 Gr. 2H	A194 Gr. 2H	A194 Gr.8
06	Gland Flange	ASTM A105N	ASTM A350 LF2	ASTM A182 F11	ASTM A316
07	Packing Gland	A479 TP316	A479 TP316	A479 TP316	A479 TP316L
08	Bonnet	ASTM A105N	ASTM A350 LF2	ASTM A182 F11	ASTM A182 F316L
09	Gland Studs	AISI 410	AISI 410	AISI410	A193 B8M
10	Bolts B/B	A193 B7	A193 B7	A193 B7	A193 B8
11	Packing	Graphoil	Graphoil	Graphoil	Graphoil
12*	Stem	A479 TP410	A479 TP304	A479 TP410	A479 TP316L
13	Gasket B/B	F316 + Graphoil	F316 + Graphoil	F316 + Graphoil	F316 + Graphoil
14*	Wedge	A479 TP410	A479 TP304	A479 TP410 + STL.6	A479 TP316L
15	Seat Ring	A479 TP410 (+STL.6**)	A479 TP304	A479 TP410 + STL.6	A479 TP316L
16	Body	ASTM A105N	ASTM A350 LF2	ASTM A182 F11	ASTM A182 F316L

* Recommended Spare Parts

(**) also available round bolted bonnet + ring joint type

1500 Lbs

FORGED STEEL GATE VALVES CLASS 1500

ANSI CLASS 1500

PRESSURE – TEMPERATURE RATINGS TO ANSI B16.34

Temperature °C	WORKING PRESSURE (bar.g)		
	ASTM A105N (a)	ASTM A182 F11 (b)	ASTM A182 SS316 (c)
-29 to 38	255.5	258.6	248.3
93	232.8	258.6	213.4
149	226.2	249.0	192.8
204	218.6	239.0	177.2
260	206.6	229.3	164.8
316	188.6	208.6	155.5
343	185.2	202.8	153.1
371	183.8	195.9	149.7
399	173.8	183.4	147.2
427	142.1	175.2	145.5
454	92.4	167.9	144.1
482	59.3	154.8	143.1
510	35.5	110.0	133.1
538	17.9	74.5	120.7
566		49.7	118.6
593		33.1	105.2
621		21.4	81.7
649		13.1	63.8

(a) Permissible, but not recommended for prolonged usage above 427 °C
 (b) Permissible, but not recommended for prolonged usage above 594 °C
 (c) For welding end valves only: Flanged end ratings terminate at 538 °C

SIZE (Reduced Bore)		DIMENSION in mm				
Inches	mm	A	B	C	D	Kg (HANDWHEEL)
1/2"	15	90	152	80	10	2.5
3/4"	20	110	180	100	14	3.8
1"	25	120	218	120	18	5.4
1-1/4"	32	130	252	140	24	8
1-1/2"	40	130	275	170	29	10.2
2"	50	150	320	170	36.5	15

SIZE (Full Bore)		DIMENSION in mm				
Inches	mm	A	B	C	D	Kg (HANDWHEEL)
1/4"	8	90	152	80	8	2.5
3/8"	10	90	152	80	10	2.5
1/2"	15	110	180	100	14	3.8
3/4"	20	120	218	120	18	5.4
1"	25	130	252	140	24	8
1-1/4"	32	130	275	170	29	10.2
1-1/2"	40	150/210	320	170	36.5	15
2"	50	210	325	170	40	15