

CAST STEEL DUAL PLATE CHECK VALVES

150 – 300 – 600 Lbs

DT-DPCV-001

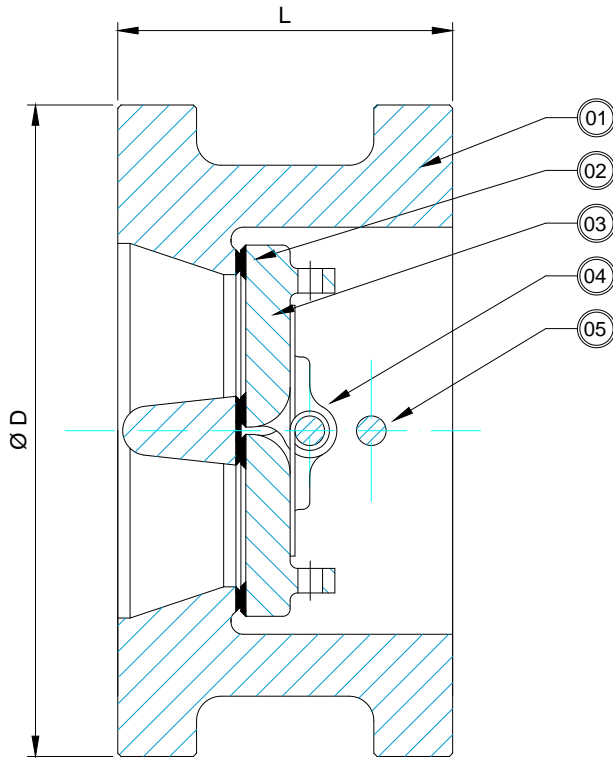

BASIC DESIGN STANDARDS

Basic Design API 594 / ANSI B16.34

Face to Face Dimension API 594

Flanges Up to 24" ANSI B16.5
From 26" MSS SP44
ANSI B16.47 API 605

Testing API 598

STANDARD DESCRIPTION

- Flow direction is stamped on body
- Wafer Type
- Suitable for mounting between flanges
- Lifting Eyebolt from 30 Kg and heavier
- Special features according to Customer's requirement
- Suitable for vertical & horizontal installation

TEST PRESSURE TO API 598 Psi/bar

Shell (water)	Seat (water)	Seat (air)
430 / 30	315 / 22	80 / 5,5

* Recommended Spare Parts

		TRIM NUMBER AS PER API 600							
No	Part Name	1	2	8	5	9	10	12	16
02	Body sealing			STL Gr.6	STL Gr.6			STL Gr.6	STL Gr.6
02	Plate sealing	410	304	410	STL Gr.6	MONEL	316	316	STL Gr.6
05	Stop Pin								
06	Pin			410	410				

BILL OF MATERIALS STANDARD ACCORDING TO ASTM									
		Carbon Steel		Alloy Steel		Stainless Steel			
No	Part Name	WCB	LCB	WC6	C5	CF8	CF8M	CF3	CF3M
01	Body	A216 WCB	A352LCB	A217WC6	A217 C5	A351 CF8	A351 CF8M	A351 CF3	A351 CF3M
03	Plates	A351 CF3M	A352 LCB	A217 WC6	A217 C5	A351 CF8	A351 CF8M	A351 CF3	A351 CF3M
04 (*)	Spring	INCONEL X750				INCONEL X750 or Stainless Steel			
07 (*)	Plug Gasket	Stainless steel + Graphite							
08	Plug	Carbon steel		Alloy steel		Stainless steel			

This document is the property of OPM ITALIA Srl. It must not be stored, reproduced or disclosed to others without written authorisation from the Company.

150 – 300 – 600 Lbs

SIZE		150 Lbs		
Inches	mm	L (RF)	Ø D	Kg
2"	50	60	104	2,0
2-1/2"	65	67	123	3,2
3"	80	73	136	4,0
4"	100	73	174	7,0
6"	150	98	222	15
8"	200	127	279	23
10"	250	146	340	39
12"	300	181	410	54
14"	350	184	451	80
16"	400	191	515	117
18"	450	203	550	140
20"	500	219	603	165
24"	600	222	717	340

300 Lbs		
L (RF)	Ø D	Kg
60	111	3,0
67	130	4,0
73	149	6,0
73	181	8,5
98	251	17
127	308	32
146	362	52
181	423	82
222	486	122
232	539	185
264	596	200
292	654	265
318	775	400

600 Lbs		
L (RF)	Ø D	Kg
60	111	4,0
67	130	5,0
73	149	8,0
79	194	11
136	267	30
165	321	50
213	430	85
229	457	135
273	492	220
305	565	360
362	613	395
368	683	515
438	790	830

CAST STEEL DUAL PLATE CHECK VALVES 150# - 300# 600#