

# CAST STEEL SWING CHECK VALVES

**300 Lbs**

**DT-CSV6D-300**

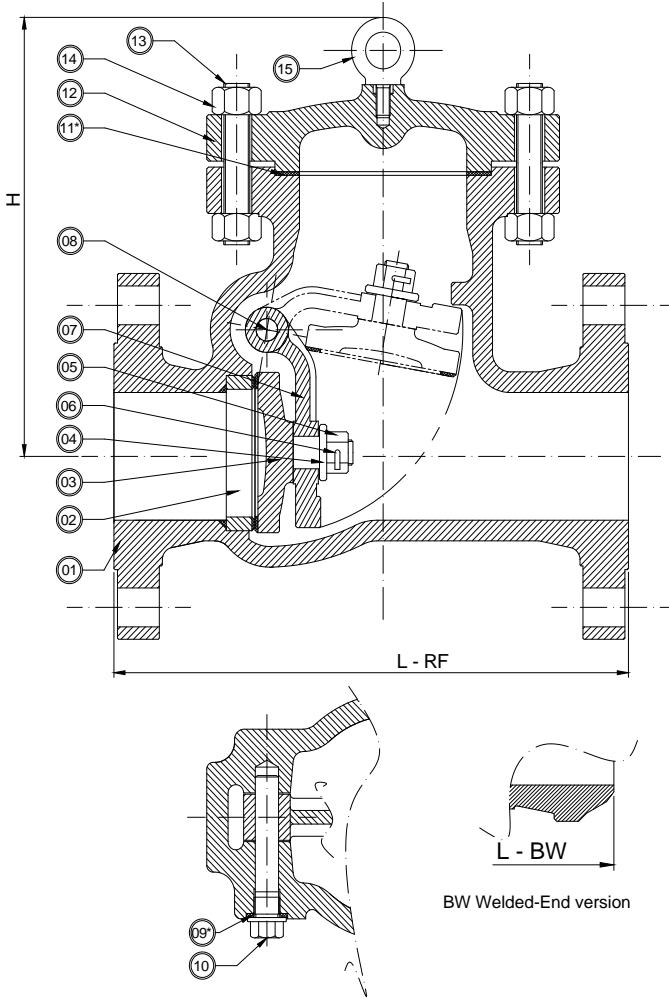

**BASIC DESIGN STANDARDS**

**Basic Design**     API 6D / ANSI B16.34

**Face to Face Dimension**     ANSI B16.10

**Flanges**     Up to 24" ANSI B16.5  
From 26" MSS SP44  
ANSI B16.47 API 605

**Butt-weld ends**     ANSI B16.25

**Testing**     API 598

**STANDARD DESCRIPTION**

- Full Opening
- Flow direction is stamped on body
- Bolted Cover Joint
- Welded Seat Ring
- Lifting Eyebolt from 30 Kg and heavier
- Suitable for vertical & horizontal installation
- Special features according to Customer's requirement
- Available accessories:
  - Outside lever with counter weight
  - Shock absorber (pneumatic cylinder)
  - Limit switch

**TEST PRESSURE TO API 598 Psi/bar**

Shell (water)	Seat (water)	Seat (air)
1100 / 76	800 / 55	80 / 5,5

\* Recommended Spare Parts

		TRIM NUMBER AS PER API 600							
No	Part Name	1	2	8	5	9	10	12	16
02	Seat Ring			STL Gr.6	STL Gr.6			STL Gr.6	STL Gr.6
03	Disc			410	STL Gr.6				STL Gr.6
04	Washer								
05	Disc Nut	410	304			MONEL	316	316	
06	Pin			410	410				
08	Disc Pin								316
10	Plug								

BILL OF MATERIALS STANDARD ACCORDING TO ASTM									
No	Part Name	Carbon Steel		Alloy Steel		Stainless Steel			
		WCB	LCB	WC6	C5	CF8	CF8M	CF3	CF3M
01	Body	A216 WCB	A352LCB	A217WC6	A217 C5	A351 CF8	A351 CF8M	A351 CF3	A351 CF3M
07	Disc Hinge	A216 WCB	A352 LCB	A217 WC6	A217 C5	A351 CF8	A351 CF8M	A351 CF3	A351 CF3M
12	Cover	A216 WCB	A352 LCB	A217 WC6	A217 C5	A351 CF8	A351 CF8M	A351 CF3	A351 CF3M
13	Bonnet Bolts	A193-B7	A320-L7	A193-B16		A193-B8			
14	Bonnet Nuts	A194-2H	A194-4	A194-4		A194-8			
11	Body / Cover Gasket	304 SS + Graphite inhibited							
09	Plug gasket	304 SS + Graphite inhibited							
15	Lifting Eyebolt	Iron Steel							

This document is the property of OPM ITALIA Srl. It must not be stored, reproduced or disclosed to others without written authorisation from the Company.

## 300 Lbs

SIZE		DIMENSION in mm			WEIGHT
Inches	mm	L (RF)	L (BW)	H	Kg
2"	50	267	267	180	24
3"	80	318	318	230	45
4"	100	356	356	270	75
6"	150	444	444	330	124
8"	200	533	533	410	190
10"	250	622	622	460	325
12"	300	711	711	550	475
14"	350	838	838	610	690
16"	400	864	864	670	900
18"	450	978	978	700	1100
20"	500	1016	1016	725	1330
22"	550	1118	1118	825	-
24"	600	1346	1346	1080	1950

For Face-to-Face dimension L (RTJ), add +16 mm from size 2" up to 18"  
add +19 mm for size 20", add +22 mm for sizes 22" and 24"

**CAST STEEL SWING CHECK VALVES CLASS 300#**