

CAST STEEL GATE VALVES

150 Lbs

DT-CGV-150

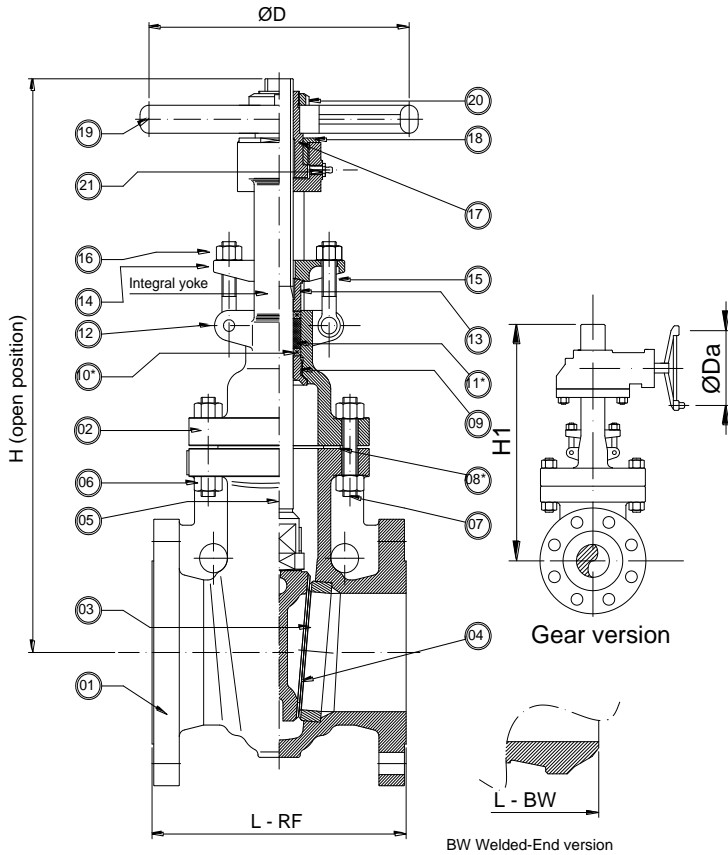

BASIC DESIGN STANDARDS

Basic Design API 600 / ANSI B16.34

Face to Face Dimension ANSI B16.10

Flanges Up to 24" ANSI B16.5
From 26" MSS SP44
ANSI B16.47 API 605

Butt-weld ends ANSI B16.25

Testing API 598

STANDARD DESCRIPTION

- Outside Screw & Yoke
- Bolted Bonnet with integral yoke up to Ø 8"
- Bolted Bonnet with bolted yoke from Ø 10"
- Welded Seat Ring
- Solid wedge up to Ø 2-1/2"
- Flexible Wedge from Ø 3" and greater
- Available with Gear Operator
- Special features according to Customer's requirement

TEST PRESSURE TO API 598 Psi/bar

Shell (water)	Seat (water)	Seat (air)
450 / 30	314 / 22	80 / 5,5

* Recommended Spare Parts

		TRIM NUMBER AS PER API 600							
No	Part Name	1	2	8	5	9	10	12	16
03	Seat Ring			STL Gr.6	STL Gr.6			STL Gr.6	STL Gr.6
04	Wedge			410	STL Gr.6				STL Gr.6
05	Stem	410	304				316		
09	Backseat					MONEL		316	
	Lantern Ring			410	410				316
13	Gland								

BILL OF MATERIALS STANDARD ACCORDING TO ASTM

No	Part Name	Carbon Steel		Alloy Steel		Stainless Steel			
		WCB	LCB	WC6	C5	CF8	CF8M	CF3	CF3M
01	Body	A216 WCB	A352LCB	A217WC6	A217 C5	A351 CF8	A351 CF8M	A351 CF3	A351 CF3M
02	Bonnet	A216 WCB	A352 LCB	A217 WC6	A217 C5	A351 CF8	A351 CF8M	A351 CF3	A351 CF3M
06	Bonnet Bolts	A193-B7	A320-L7	A193-B16		A193-B8			
07	Bonnet Nuts	A194-2H	A194-4	A194-4		A194-8			
08	Body / Bonnet Gasket	304 SS + Graphite inhibited							
10-11	Stem Packing	Braided and Flexible Graphite							
12	Eyebolts Pin	A276-410							
14	Gland Flange	A216 WCB	A352 LCB	A217 WC6	A217 C5	A351 CF8	A351 CF8M	A351 CF3	A351 CF3M
15	Gland Eyebolts	A193-B7	A320-L7	A193-B16		A193-B8			
16	Gland Nuts	A194-2H	A194-4	A194-4		A194-8			
17	Stem Nut	ASTM A439-D2							
18	Retaining Nut	Carbon Steel				410			
19	Hand Wheel					Ductile Iron or Steel			
20	Hand Wheel Nut	Carbon Steel				410			
21	Grease Nipple	Stainless Steel							

This document is the property of OPM Italia Srl. It must not be stored, reproduced or disclosed to others without written authorisation from the Company.

CAST STEEL GATE VALVES

150 Lbs

CAST STEEL GATE VALVES CLASS 150#

SIZE		DIMENSION in mm						WEIGHT	
Inches	mm	L (RF)	L (BW)	H Open	H1	Ø D	Ø Da	Kg (HANDWHEEL)	Kg (GEAR OPERATOR)
2"	50	178	178	390	-	200	-	19	-
2-1/2"	65	190	190	520	-	250	-	24	-
3"	80	203	203	530	-	250	-	33	-
4"	100	229	229	605	-	350	-	49	-
6"	150	267	267	780	-	350	305	87	-
8"	200	292	292	960	-	350	305	132	-
10"	250	330	330	1210	-	450	305	203	-
12"	300	356	356	1415	1465	500	305	265	291
14"	350	381	381	1532	1600	600	305	490	516
16"	400	406	406	1765	1820	600	305	535	561
18"	450	432	432	1965	2015	600	460	640	689
20"	500	457	457	2130	2180	600	460	780	830
22"	550	508	508	2385	2450	700	460	990	1040
24"	600	508	508	2565	2630	700	460	1190	1240
28"	700	610	610	-	3350	-	460	1931	-
30"	750	610	610	-	3400	-	460	2380	-
32"	800	660	660	-	3450	-	460	2490	-

For Face-to-Face dimension L (RTJ), add +13 mm from size 2" up to 24"

ANSI CLASS 150 **PRESSURE – TEMPERATURE RATINGS TO ANSI B16.34**

Temperature ° C	WORKING PRESSURE (bar.g)									
	Carbon Steel		Alloy Steel				Stainless Steel			
	WCB (a)	LCB (b)	WC6 (c)	WC9 (c)	C5 (g)	C12 (g)	CF8 (d)	CF8M (d)	CF3 (e)	CF3M (f)
-29 to 38	19.6	18.4	19.8	19.8	20	20	19	19	19	19
50	19.2	18.2	19.5	19.5	19.5	19.5	18.3	18.4	18.3	18.4
100	17.7	17.4	17.7	17.7	17.7	17.7	15.7	16.2	15.7	16.2
150	15.8	15.8	15.8	15.8	15.8	15.8	14.2	14.8	14.2	14.8
200	13.8	13.8	13.8	13.8	13.8	13.8	13.2	13.7	13.2	13.7
250	12.1	12.1	12.1	12.1	12.1	12.1	12.1	12.1	12.1	12.1
300	10.2	10.2	10.2	10.2	10.2	10.2	10.2	10.2	10.2	10.2
350	8.4	8.4	8.4	8.4	8.4	8.4	8.4	8.4	8.4	8.4
400	6.5	6.5	6.5	6.5	6.5	6.5	6.5	6.5	6.5	6.5
425	5.5	5.5	5.5	5.5	5.5	5.5	5.5	5.5	5.5	5.5
450	4.6	4.6	4.6	4.6	4.6	4.6	4.6	4.6	4.6	4.6
500	2.8	2.8	2.8	2.8	2.8	2.8	2.8	2.8	2.8	2.8
538	1.4	1.4	1.4	1.4	1.4	1.4	1.4	1.4	1.4	1.4
550	-	-	1.4	1.4	1.4	1.4	1.4	1.4	1.4	1.4
600	-	-	1.4	1.4	1.4	1.4	1.4	1.4	1.4	1.4
650	-	-	-	-	-	-	1.4	1.4	1.4	1.4
700	-	-	-	-	-	-	1.4	1.4	1.4	1.4
750	-	-	-	-	-	-	1.4	1.4	1.4	1.4
800	-	-	-	-	-	-	-	-	-	-

- (a) Permissible, but not recommended for prolonged usage above 425 °C
- (b) Not be used over 345 °C.
- (c) Permissible, but not recommended for prolonged usage above 595 °C Flanged End valve ratings terminate at 538°C.
- (d) At temperature above 538 °C, use only when carbon content is 0.04 % or higher. Flanged End valve ratings terminate at 538°C.
- (e) Not be used over 425 °C. Flanged End valve ratings terminate at 538°C.
- (f) Not be used over 455 °C. Flanged End valve ratings terminate at 538°C.
- (g) Flanged End valve ratings terminate at 538°C.