

150 - 300 - 600 - 900 - 1500 – 2500 Lbs

**DT-BV-005
FORGED**

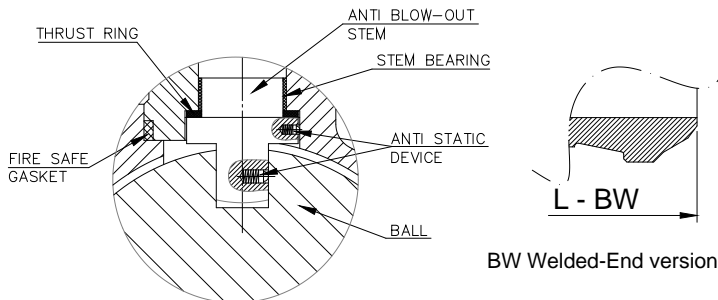
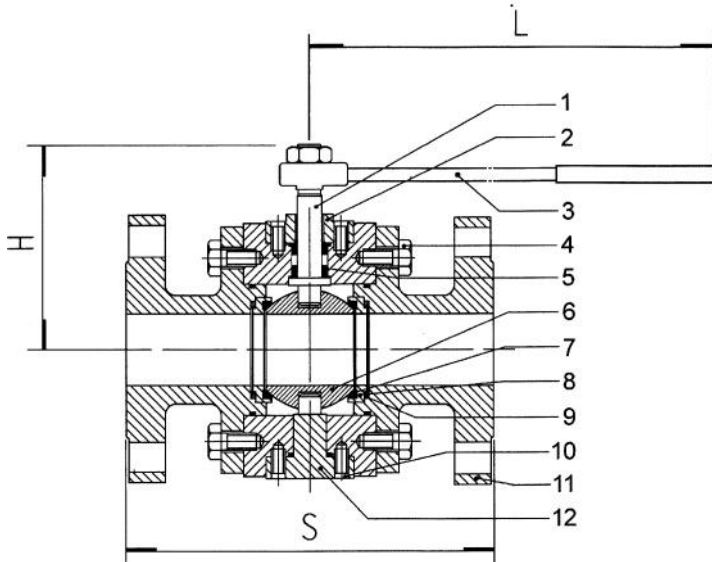

BASIC DESIGN STANDARDS

Basic Design	API 6D / ANSI B16.34
Face-to-face Dimension	API 6D / ANSI B16.10
Flanges	ANSI B16.5
Testing	API 6D

STANDARD DESCRIPTION

- Trunnion mounted Ball valve - 3 pieces
- Soft Seated – Anti blowout stem
- Full Port or Reduced Port
- Fire safe design to API 607
- Antistatic device
- Lever Operator OR
- Gear box Operator
- Special features according to Customer's requirement.

TEST PRESSURE TO API 598 bar.g

Rating	Shell (water)	Seat (water)	Seat (air)
150 #	30	22	6
300 #	77	57	6
600 #	153	113	6
900#	230	170	6
1500#	383	281	6

* Recommended Spare Parts

BILL OF MATERIALS STANDARD ACCORDING TO ASTM

No	Part Name	A105	LF2	F316
01	Stem	ASTM A105N + ENP	ASTM A182 F6a	ASTM A182 F316
02	Gland	ASTM A105N + ENP	ASTM A182 F6a	ASTM A182 F316
03	Wrench	Carbon Steel	Carbon Steel	Carbon Steel
04	Stud Bolt	ASTM A193 B7M	ASTM A193 B16	ASTM A193 B8
05	Stem Seal	O-RING	O-RING	O-RING
06	Ball	ASTM A105 + ENP	ASTM A350 LF2 + ENP	ASTM A182 F316
07	Seat	PTFE / DEVLON	PTFE / DEVLON	PTFE / DEVLON
08	Seat Ring	Carbon Steel	Low Temp. Carbon Steel	Stainless steel
09	Spring	Spring steel	Spring steel	Spring steel
10	Screw	ASTM A193 B7M	ASTM A193 B16	ASTM A193 B8
11	Body	ASTM A105	ASTM A350 LF2	ASTM A182 F316
12	Stem Below	ASTM A182 F6a	ASTM A182 F6a	ASTM A182 F316

150 - 300 - 600 - 900 - 1500 – 2500 Lbs

	SIZE		DIMENSION in mm			WEIGHT
	Inches	mm	S (RF)	H	L	Kg
Class 150 #	2"	50	178	168	250	15
	2 1/2"	65	191	168	300	20
	3"	80	203	200	400	33
	4"	100	229	231	430	50
	6"	150	394	280	--	159
	8"	200	457	313	--	255
	10"	250	533	362	--	440
	12"	300	610	400	--	680
	14"	350	686	511	--	870
	16"	400	762	548	--	1200
	20"	500	914	624	--	1760
	24"	600	1067	681	--	2900
	26"	650	1143	720	--	3350
	28"	700	1246	760	--	4200
	30"	750	1295	780	--	5060
	32"	800	1372	810	--	5750
	36"	900	1524	900	--	7900
	40"	1000	1727	1130	--	11500
42"	1050	1829	1180	--	12700	
48"	1200	1995	1300	--	19000	

	SIZE		DIMENSION in mm			WEIGHT
	Inches	Mm	S (RF)	H	L	Kg
Class 300 #	2"	50	216	165	300	25
	3"	80	283	193	400	45
	4"	100	305	231	475	70
	6"	150	403	329	700	180
	8"	200	502	393	--	310
	10"	250	568	411	--	530
	12"	300	648	441	--	800
	14"	350	762	481	--	1000
	16"	400	838	598	--	1390
	20"	500	991	708	--	2000
	24"	600	1143	727	--	3200
	30"	750	1397	815	--	6160
	32"	800	1524	848	--	6880
	36"	900	1727	1000	--	9300
	40"	1000	1930	1170	--	12400
	42"	1050	2083	1260	--	14400
	48"	1200	2170	1400	--	20900

FORGED STEEL TRUNNION MOUNTED BALL VALVES CLASS 150 - 300

150 - 300 - 600 - 900 - 1500 – 2500 Lbs

	SIZE		DIMENSION in mm			WEIGHT
	Inches	Mm	S (RF)	H	L	Kg
Class 600 #	2"	50	292	176	400	40
	3"	80	356	195	750	78
	4"	100	432	210	1000	110
	6"	150	559	280	1500	300
	8"	200	660	322	--	450
	10"	250	787	390	--	750
	12"	300	838	500	--	1060
	14"	350	889	550	--	1330
	16"	400	991	600	--	1950
	20"	500	1194	645	--	3300
	24"	600	1397	740	--	4500
	30"	750	1651	1000	--	7700
	32"	800	1778	1060	--	8900
	36"	900	2083	1110	--	11900
	40"	1000	2159	1180	--	16500
	42"	1050	2175	1230	--	18500
48"	1200	2435	1470	--	27200	

	SIZE		DIMENSION in mm			WEIGHT
	Inches	Mm	S (RF)	H	L	Kg
Class 900 #	2"	50	368	180	400	57
	3"	80	381	195	--	90
	4"	100	457	225	--	130
	6"	150	610	290	--	440
	8"	200	737	360	--	600
	10"	250	838	470	--	940
	12"	300	965	522	--	1390
	14"	350	1029	560	--	1800
	16"	400	1130	610	--	2400
	20"	500	1321	660	--	4100
	24"	600	1549	880	--	6500
	30"	750	1880	1100	--	13300
	32"	800	2032	1170	--	14700
	36"	900	2286	1250	--	24200

CAST STEEL TRUNNION MOUNTED BALL VALVES CLASS 600 - 900

150 - 300 - 600 - 900 - 1500 – 2500 Lbs

Class 1500 #	SIZE		DIMENSION in mm			WEIGHT
	Inches	Mm	S (RF)	H	L	Kg
	2"	50	368	170	400	85
3"	80	470	210	--	135	
4"	100	546	240	--	260	
6"	150	705	318	--	530	
8"	200	832	400	--	880	
10"	250	991	490	--	1400	
12"	300	1130	540	--	2310	
14"	350	1257	615	--	2820	
16"	400	1384	694	--	3400	
20"	500	1664	800	--	5540	
24"	600	1943	1020	--	8900	

Class 2500#	SIZE		DIMENSION in mm			WEIGHT
	Inches	Mm	S (RF)	H	L	Kg
	2"	50	451	180	400	108
3"	80	578	222	--	240	
4"	100	673	258	--	455	
6"	150	914	340	--	930	
8"	200	1022	411	--	1580	
10"	250	1270	510	--	2500	
12"	300	1422	600	--	4000	

CAST STEEL TRUNNION MOUNTED BALL VALVES CLASS 1500 - 2500