

150 - 300 - 600 Lbs

**DT-BV-004-
FORGED**

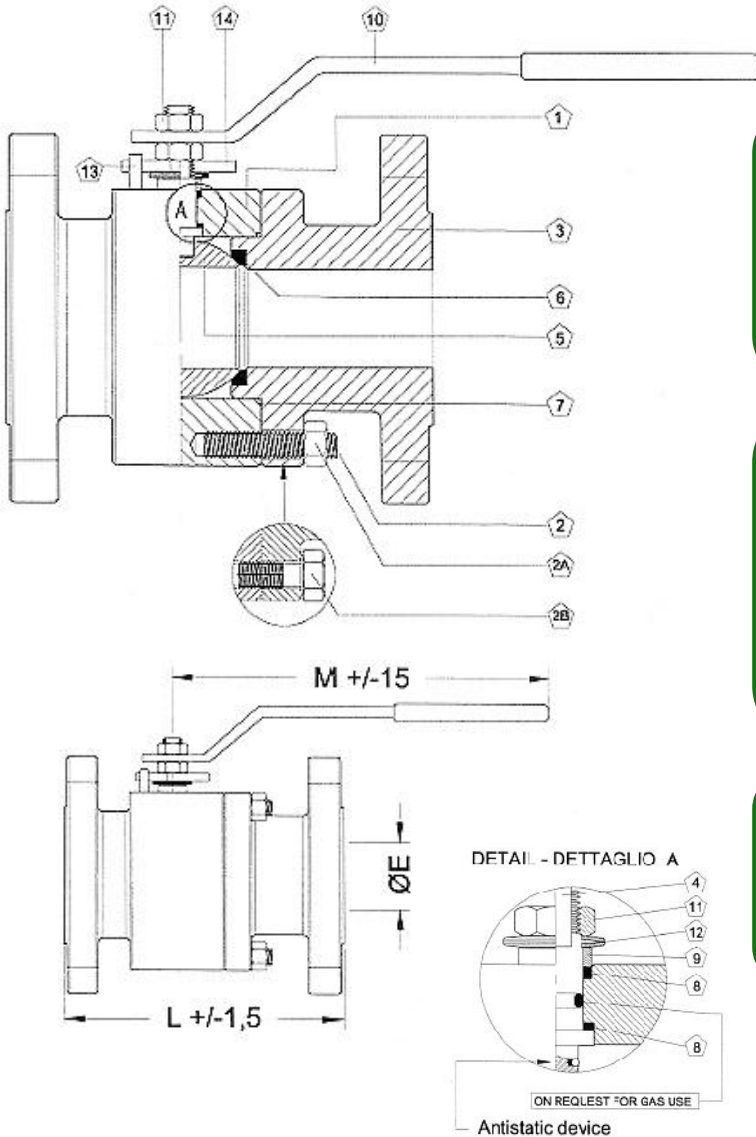

BASIC DESIGN STANDARDS

Basic Design	API 6D / ANSI B16.34
Face-to-face Dimension	API 6D / ANSI B16.10
Flanges	ANSI B16.5
Testing	API 6D

STANDARD DESCRIPTION

- Floating Type – split Body 2 pieces
- Soft Seated – Anti blowout stem
- Full Port (or Reduced Port on request)
- Fire safe design to API 607
- Antistatic device
- Lever operator up to NPS 4"
- Gear box Operator on request
- Special features according to Customer's requirement.

TEST PRESSURE TO API 598 bar.g

Rating	Shell (water)	Seat (water)	Seat (air)
150 #	30	22	6
300 #	77	57	6
600 #	153	113	6

* Recommended Spare Parts

BILL OF MATERIALS STANDARD ACCORDING TO ASTM

No	Part Name	A105	LF2	F316
01	Body	ASTM A105	ASTM A350 LF2	ASTM A182 316
02	Tie Rod	ASTM A193 B7	ASTM A320 L7	ASTM A193 B8M
02A	Nut	ASTM A194 2H	ASTM A194 2H	ASTM A194 Gr.8M
02B	Bolt	ASTM A193 B7	ASTM A320 L7	ASTM A193 B8M
03	Closure	ASTM A105	ASTM A350 LF2	ASTM A182 316
04	Stem	ASTM A182 F6a	ASTM A350 LF2 + ENP	ASTM A182 316
05	Ball	ASTM A105 + ENP	ASTM A350 LF2 + ENP	ASTM A182 316
06	Seat (*)	P.T.F.E.	P.T.F.E.	P.T.F.E.
07	Body Gasket (*)	P.T.F.E.	P.T.F.E.	P.T.F.E.
08	Stem seal	P.T.F.E.	P.T.F.E.	P.T.F.E.
09	Gland	ASTM A105 + ENP	ASTM A105 + ENP	ASTM A182 316
10	Wrench/Lever	Galvanized steel	Galvanized steel	Galvanized steel
11	Nut	ASTM A194 2HM	ASTM A194 2HM	ASTM A194 Gr.8M
12	Washer	Carbon Steel	Carbon Steel	Stainless Steel
13	Stop Pin	Carbon Steel	Carbon Steel	Stainless Steel
15	Stop Plate	Carbon Steel	Carbon Steel	Stainless Steel

150 - 300 - 600 Lbs

Class 150 #	SIZE		DIMENSION in mm			WEIGHT
	Inches	mm	L (RF)	M	E	Kg
	1/2"	15	108	150	14	2.5
3/4"	20	117	185	19	4	
1"	25	127	185	25	6	
1-1/4"	32	140	280	32	8	
1-1/2"	40	165	280	38	13	
2"	50	178	280	48	17	
2-1/2"	65	190	380	65	22	
3"	80	203	380	76	30	
4"	100	229	480	95	40	
5"	125	254	480	119	50	
6"	150	267	480	145	71	

Class 300 #	SIZE		DIMENSION in mm			WEIGHT
	Inches	mm	L (RF)	M	E	Kg
	1/2"	15	140	150	14	4.7
3/4"	20	152	185	19	5.8	
1"	25	165	185	25	7	
1-1/4"	32	180	280	32	11.3	
1-1/2"	40	191	280	38	14	
2"	50	216	280	48	20	
2-1/2"	65	241	380	65	25	
3"	80	283	380	76	40	
4"	100	305	480	95	57	
5"	125	381	480	119	72	
6"	150	403	480	145	91	

Class 600 #	SIZE		DIMENSION in mm			WEIGHT
	Inches	mm	L (RF)	M	E	Kg
	1/2"	15	165	150	14	4.5
3/4"	20	190	185	19	5.5	
1"	25	216	185	25	10	
1-1/4"	32	228.5	280	32	11.5	
1-1/2"	40	241.5	280	38	18.5	
2"	50	292	280	48	23	
2-1/2"	65	330	380	65	32	
3"	80	355.5	380	76	40	
4"	200	432	380	95	85	

FORGED STEEL FLOATING BALL VALVES CLASS 150 - 300 - 600 #