

CAST ST. FLOATING BALL VALVES

150 - 300 - 600 Lbs

DT-BV-004-CAST

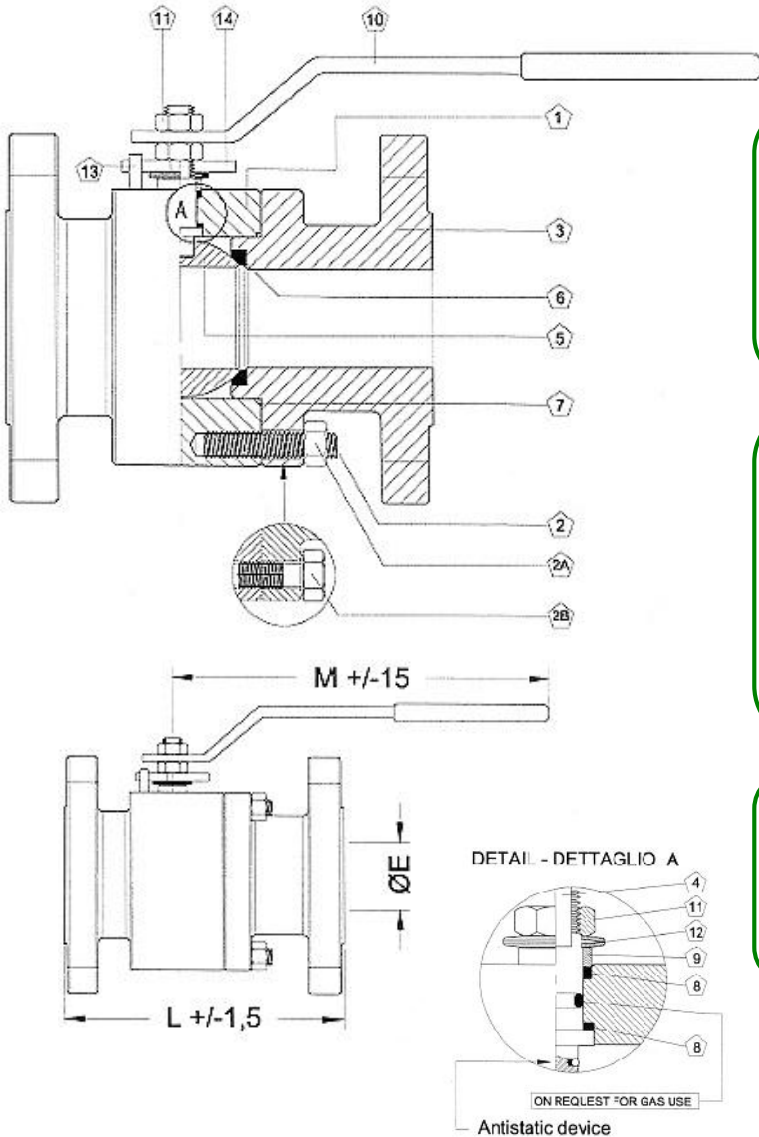

BASIC DESIGN STANDARDS

Basic Design API 6D / ANSI B16.34

Face-to-face Dimension API 6D / ANSI B16.10

Flanges ANSI B16.5

Testing API 6D

STANDARD DESCRIPTION

- Floating Type – split Body 2 pieces
- Soft Seated – Anti blowout stem
- Full Port (or Reduced Port on request)
- Fire safe design to API 607
- Antistatic device
- Lever operator up to NPS 4"
- Gear box Operator on request
- Special features according to Customer's requirement.

TEST PRESSURE TO API 598 bar.g

Rating	Shell (water)	Seat (water)	Seat (air)
150 #	30	22	6
300 #	77	57	6
600 #	153	113	6

This document is the property of OPM Italia Srl. It must not be stored, reproduced or disclosed to others without written authorisation from the Company.

* Recommended Spare Parts

BILL OF MATERIALS STANDARD ACCORDING TO ASTM

No	Part Name	A216 WCB	A351 CF8M	A351 CF3M
01	Body	ASTM A216	ASTM A351 CF8M	ASTM A351 CF3M
02	Tie Rod	ASTM A193 B7M	ASTM A320 B8M	ASTM A320 B8M
02A	Nut	ASTM A194 2HM	ASTM A194 8M	ASTM A194 8M
02B	Bolt	ASTM A193 B7M	ASTM A320 B8M	ASTM A320 B8M
03	Closure	ASTM A216	ASTM A351 CF8M	ASTM A351 CF3M
04	Stem	ASTM A182 F6a	ASTM A182 F316	ASTM A182 F316L
05	Ball	ASTM A105 + ENP	ASTM A182 F316	ASTM A182 F316L
06	Seat (*)	P.T.F.E.	P.T.F.E.	P.T.F.E.
07	Body Gasket (*)	P.T.F.E.	P.T.F.E.	P.T.F.E.
08	Stem seal	P.T.F.E.	P.T.F.E.	P.T.F.E.
09	Gland	ASTM A479 TP410	ASTM A479 TP410	ASTM A479 TP316
10	Wrench/Lever	Galvanized steel	Galvanized steel	Galvanized steel
11	Nut	ASTM A194 2HM	ASTM A194 8M	ASTM A194 Gr.8M
12	Washer	Carbon Steel	Stainless Steel	Stainless Steel
13	Stop Pin	Carbon Steel	Stainless Steel	Stainless Steel
15	Stop Plate	Carbon Steel	Stainless Steel	Stainless Steel

150 - 300 - 600 Lbs

Class 150 #	SIZE		DIMENSION in mm			WEIGHT
	Inches	mm	L (RF)	M	E	Kg
	1/2"	15	108	140	14	2
3/4"	20	117	140	19	2.5	
1"	25	127	140	25	3.5	
1-1/4"	32	140	180	32	6.5	
1-1/2"	40	165	180	38	7.5	
2"	50	178	200	48	9	
2-1/2"	65	190	300	65	14	
3"	80	203	300	76	19	
4"	100	229	480	95	36	
5"	125	254	480	119	50	
6"	150	394	600	145	79	
8"	200	457	800	180	160	

Class 300 #	SIZE		DIMENSION in mm			WEIGHT
	Inches	mm	L (RF)	M	E	Kg
	1/2"	15	140	140	14	2.5
3/4"	20	152	140	19	3.6	
1"	25	165	140	25	5	
1-1/4"	32	178	180	32	8.5	
1-1/2"	40	190	180	38	10	
2"	50	216	200	48	14	
2-1/2"	65	241	300	65	22	
3"	80	283	300	76	28	
4"	100	305	480	95	46	
5"	125	381	480	119	72	
6"	150	403	600	145	104	
8"	200	502	800	180	200	

Class 600 #	SIZE		DIMENSION in mm			WEIGHT
	Inches	mm	L (RF)	M	E	Kg
	1/2"	15	165	150	14	4.5
3/4"	20	190	185	19	5.5	
1"	25	216	185	25	10	
1-1/4"	32	228.5	280	32	11.5	
1-1/2"	40	241.5	280	38	18.5	
2"	50	292	280	48	23	
2-1/2"	65	330	380	65	32	
3"	80	355.5	380	76	40	
4"	200	432	380	95	85	

CAST STEEL FLOATING BALL VALVES CLASS 150 - 300 - 600