

FORGED STEEL BALL VALVES

800 Lbs

DT-BV-001

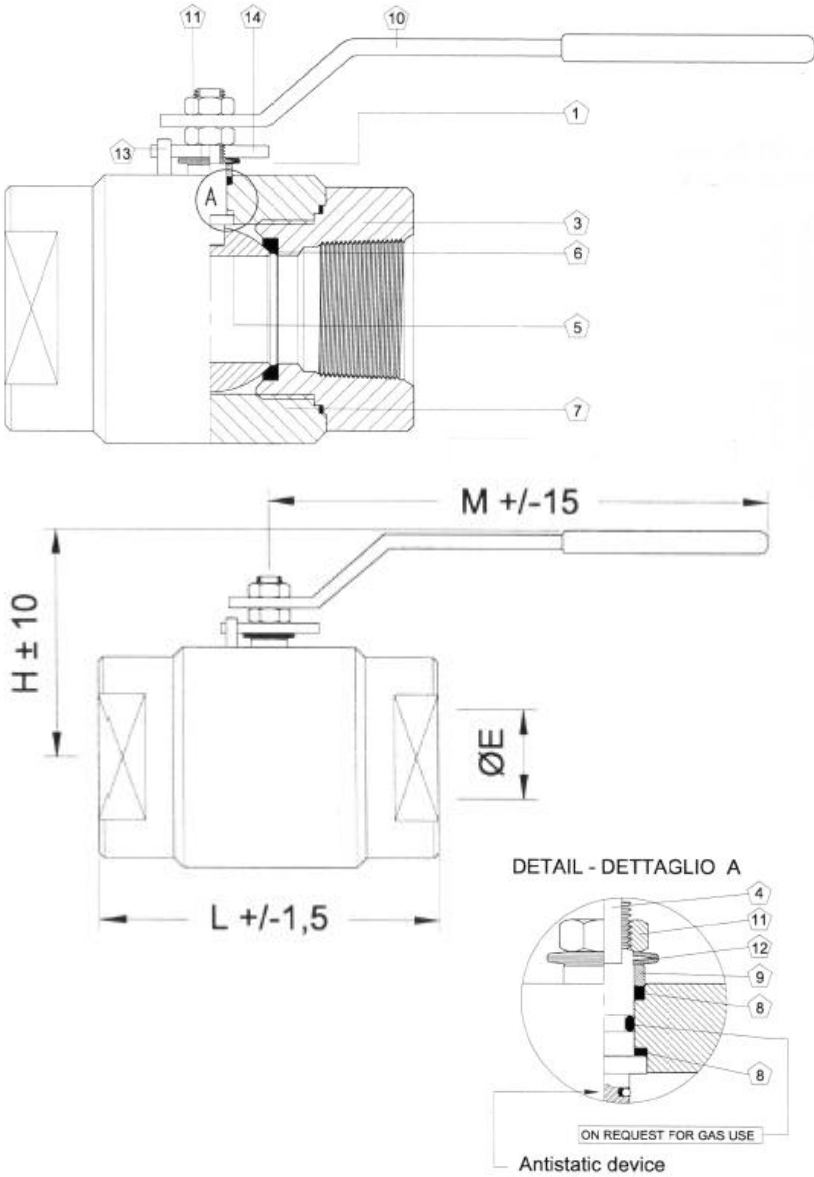

BASIC DESIGN STANDARDS

Basic Design	<u>BS 5351</u>
Face-to-face Dimension	<u>Mfr Std</u>
Screwed Ends	ANSI B1.20.1 (NPT)
Socket Weld Ends	ISO 7/1 (BSP)
Testing	ANSI B16.11 (SW)
	BS 5351

STANDARD DESCRIPTION

- Floating Type – two pieces body
- Soft Seated – Anti blowout stem
- Full Port
- Fire safe design to API 607
- Antistatic device
- SW ends with welded nipples sch. 80
- Lever operator
- Reduced Port available
- Special features according to Customer's requirement.

TEST PRESSURE TO API 598 bar

Shell (water)	Seat (water)	Seat (air)
204	150	6

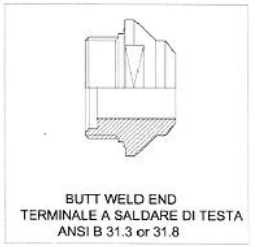
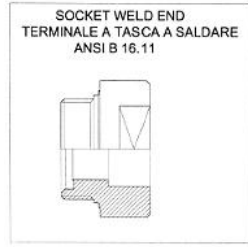

* Recommended Spare Parts

BILL OF MATERIALS STANDARD ACCORDING TO ASTM				
No	Part Name	Carbon Steel		Stainless Steel
		A105N / 304	A105N / 316	316 / 316
01	Body	ASTM A105N	ASTM A105N	ASTM A182 F316
03	Closure	ASTM A105N	ASTM A105N	ASTM A182 F316
04	Stem	ASTM A479 TP304	ASTM A479 TP316	ASTM A479 TP316
05	Ball	ASTM A479 TP304	ASTM A479 TP316	ASTM A479 TP316
06	Seat (*)	P.T.F.E.	P.T.F.E.	P.T.F.E.
07	Body Gasket (*)	P.T.F.E.	P.T.F.E.	P.T.F.E.
08	Stem seal	P.T.F.E.	P.T.F.E.	P.T.F.E.
09	Gland	ASTM A479 TP304	ASTM A479 TP316	ASTM A479 TP316
10	Wrench/Lever	Galvanized Steel	Galvanized Steel	Stainless Steel
11	Wrench nut	Galvanized Steel	Galvanized Steel	Stainless Steel
12	Washer	Galvanized Steel	Galvanized Steel	Stainless Steel
13	Limit Pin	Galvanized Steel	Galvanized Steel	Stainless Steel
14	Retainer Plate	Galvanized Steel	Galvanized Steel	Stainless Steel

** Also available 1500# rating: SEAT std: **DELIRIN**

This document is the property of OPM Italia Srl. It must not be stored, reproduced or disclosed to others without written authorisation from the Company.

FORGED STEEL BALL VALVES

800 Lbs

FORGED STEEL BALL VALVES CLASS 800 #

SIZE		DIMENSION in mm				WEIGHT
Inches	mm	Ø Bore	L (+/- 1,5)	H	Lo	Kg
1/4"	6	11	65	65	130	0,5
3/8"	10	11	65	65	130	0,6
1/2"	15	14	75	70	130	0,8
3/4"	20	19	90	85	180	1,5
1"	25	25	100	85	180	2,1
1-1/4"	32	32	115	100	280	3,0
1-1/2"	40	38	128	110	280	3,9
2"	50	48	150	115	280	6,8
2-1/2"	65	65	195	145	355	13
3"	80	76	203	150	355	16
4"	100	95	290	165	410	28

The above dimensions are only for Screwed ends type.

SIZE		DIMENSION in mm				WEIGHT
Inches	mm	Ø Bore	L (+/- 1,5)	H	Lo	Kg
1/4"	6	11	165	65	130	0,6
3/8"	10	11	165	65	130	0,7
1/2"	15	14	175	70	130	0,9
3/4"	20	19	190	85	180	1,7
1"	25	25	200	85	180	2,2
1-1/4"	32	32	215	100	280	3,1
1-1/2"	40	38	228	110	280	4,1
2"	50	48	250	115	280	7,0

The above dimensions are for Socket Weld ends with nipples.

